

ELECTRIC TOOL PARTS LIST

■ DRILL

2016-10-21

Model D 10VC3

(E1)

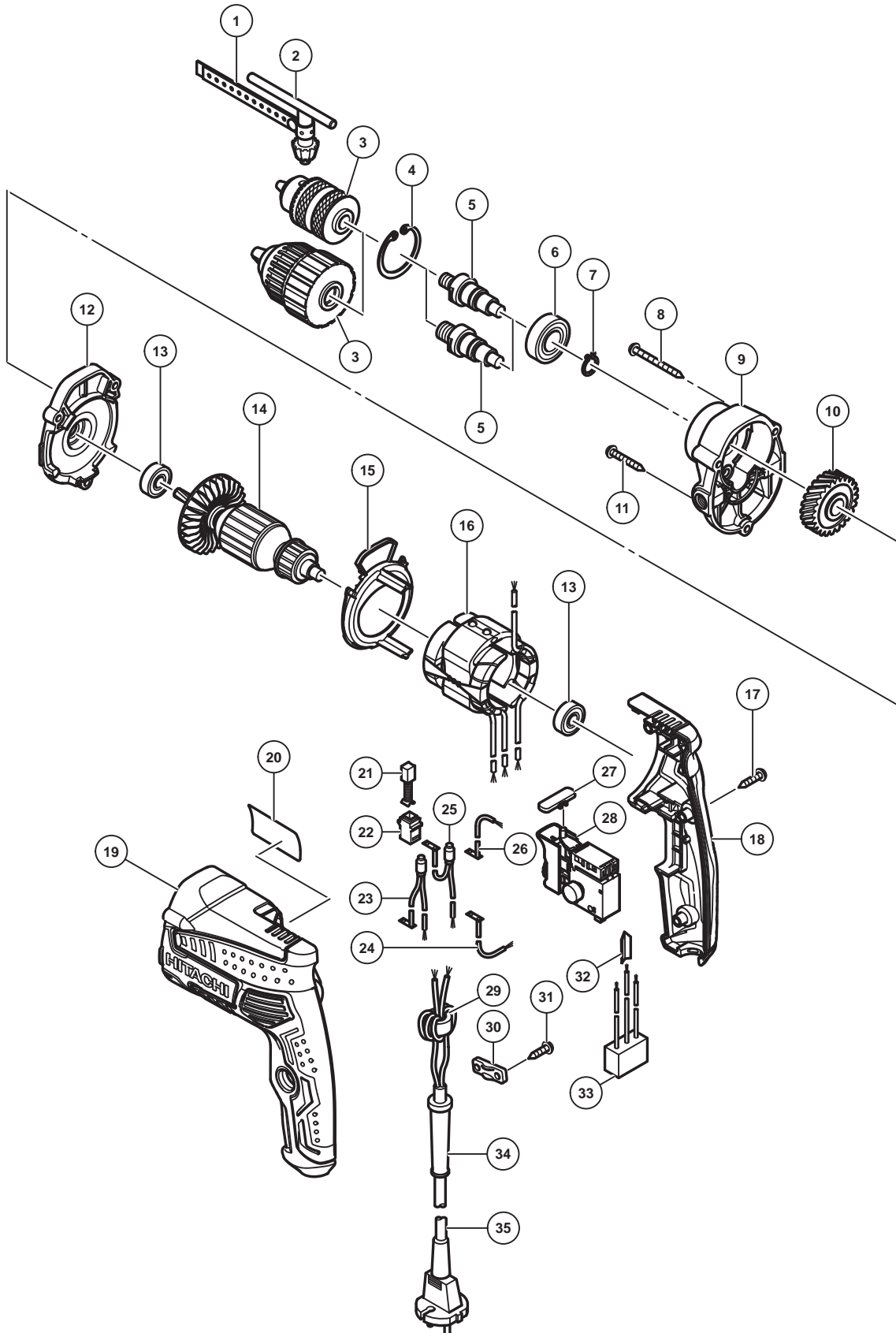

PARTS

D 10VC3

ITEM NO.	CODE NO.	DESCRIPTION	NO. USED	REMARKS
* 1	950288	VINYL BAND	1	FOR INA,HKG,SAF,CHN,TPE,NZL
* 2	980057	CHUCK WRENCH 10TL2	1	FOR INA,HKG,SAF,TPE,NZL
* 2	987576	CHUCK WRENCH FOR 13VLB-D,13VLR-D	1	FOR CHN
* 3	323250	DRILL CHUCK 10TLRK-N (W/O CHUCK WRENCH)	1	
* 3	950292	DRILL CHUCK 10TLRA	1	INCLUD.2 FOR INA,HKG,SAF,TPE,NZL
* 3		DRILL CHUCK 13VLRC-D	1	INCLUD.2 FOR CHN SUPPLIED WITH ITEM NO.601
4	948001	RETAINING RING FOR D32 HOLE	1	
* 5	370711	SPINDLE (A)	1	
* 5	370712	SPINDLE (B)	1	FOR CHN
6	6002VV	BALL BEARING 6002VVCMP2L	1	
7	939544	RETAINING RING FOR D15 SHAFT (10 PCS.)	1	
8	301815	TAPPING SCREW (W/FLANGE) D4 X 45 (BLACK)	2	
9	370710	GEAR COVER (A)	1	
10	370713	GEAR (A)	1	
11	305490	TAPPING SCREW (W/FLANGE) D4 X 30 (BLACK)	1	
12	370709	INNER COVER	1	
13	333945	BALL BEARING 608VV	2	
* 14	361051C	ARMATURE (B) 110V	1	
* 14	361051D	ARMATURE (B) 220V	1	
* 14	361051E	ARMATURE (B) 230V	1	
* 14	361051F	ARMATURE (B) 240V	1	
15	370708	FAN GUIDE	1	
* 16	340960C	STATOR 110V	1	
* 16	340960D	STATOR 220V	1	
* 16	340960E	STATOR 230V	1	
* 16	340960F	STATOR 240V	1	
17	301653	TAPPING SCREW (W/FLANGE) D4 X 20 (BLACK)	3	
18	370707	HANDLE COVER	1	
19	370706	HOUSING	1	
20		NAME PLATE	1	
21	999041	CARBON BRUSH (1 PAIR)	2	
22	955203	BRUSH HOLDER	2	
* 23	370718	CHOKE COIL (BROWN)	1	FOR EUROPE,GBR (230V),AUS,NZL,SAF,TUR,CHN
* 23	370703	CHOKE COIL (BROWN)	1	FOR GBR (110),TPE
* 24	370705	INTERNAL WIRE (BROWN)	1	FOR SIN,UAE,INA,HKG,MAL
* 25	370717	CHOKE COIL (BLUE)	1	FOR EUROPE,GBR (230),AUS,NZL,SAF,TUR,CHN
* 25	370702	CHOKE COIL (BLUE)	1	FOR GBR (110V),TPE
* 26	370704	INTERNAL WIRE (BLUE)	1	FOR SIN,UAE,INA,HKG,MAL
27	321628	PUSHING BUTTON	1	
* 28	371194	SWITCH	1	
* 28	370701	SWITCH	1	FOR GBR (110V),SIN (110V),TPE
* 29	334379	FERRITE CORE	1	FOR EUROPE,GBR,AUS,NZL,SAF,TUR,CHN,TPE
30	937631	CORD CLIP	1	
31	984750	TAPPING SCREW (W/FLANGE) D4 X 16	2	
* 32	992635	EARTH TERMINAL	1	FOR EUROPE,GBR,AUS,NZL,SAF,TUR,CHN,TPE
* 33	994273	NOISE SUPPRESSOR	1	FOR EUROPE,GBR (230V),AUS,NZL,SAF,TUR,CHN
* 33	370895	NOISE SUPPRESSOR	1	FOR GBR (110V),TPE
* 34	953327	CORD ARMOR D8.8	1	
* 34	938051	CORD ARMOR D10.1	1	

PARTS

D 10VC3

ITEM NO.	CODE NO.	DESCRIPTION	NO. USED	REMARKS	
*	35 500409Z	CORD	1	(CORD ARMOR D8.8)	
*	35 500505Z	CORD	1	(CORD ARMOR D8.8) FOR GBR (230V), SIN (230V),UAE,HKG,MAL	
*	35 500461Z	CORD	1	(CORD ARMOR D8.8) FOR GBR (110V)	
*	35 930051	CORD	1	(CORD ARMOR D10.1) FOR SIN (110V)	
*	35 500439Z	CORD	1	(CORD ARMOR D8.8) FOR AUS,NZL	
*	35 500468Z	CORD	1	(CORD ARMOR D8.8) FOR CHN	
*	35 323974	CORD	1	(CORD ARMOR D10.1) FOR TPE	

OPTIONAL ACCESSORIES

ITEM NO.	CODE NO.	DESCRIPTION	NO. USED	REMARKS	
*	601 321814	DRILL CHUCK 13VLRB-D	1	INCLUD.2 FOR CHN	
	602 982593	HOOK	1		
	603 370716	HOOK (A)	1		
	604 981205	SIDE HANDLE FOR M10	1		