

ELECTRIC TOOL PARTS LIST

■ ROTARY HAMMER Model DH 45MR

2005 · 9 · 8
(E1)

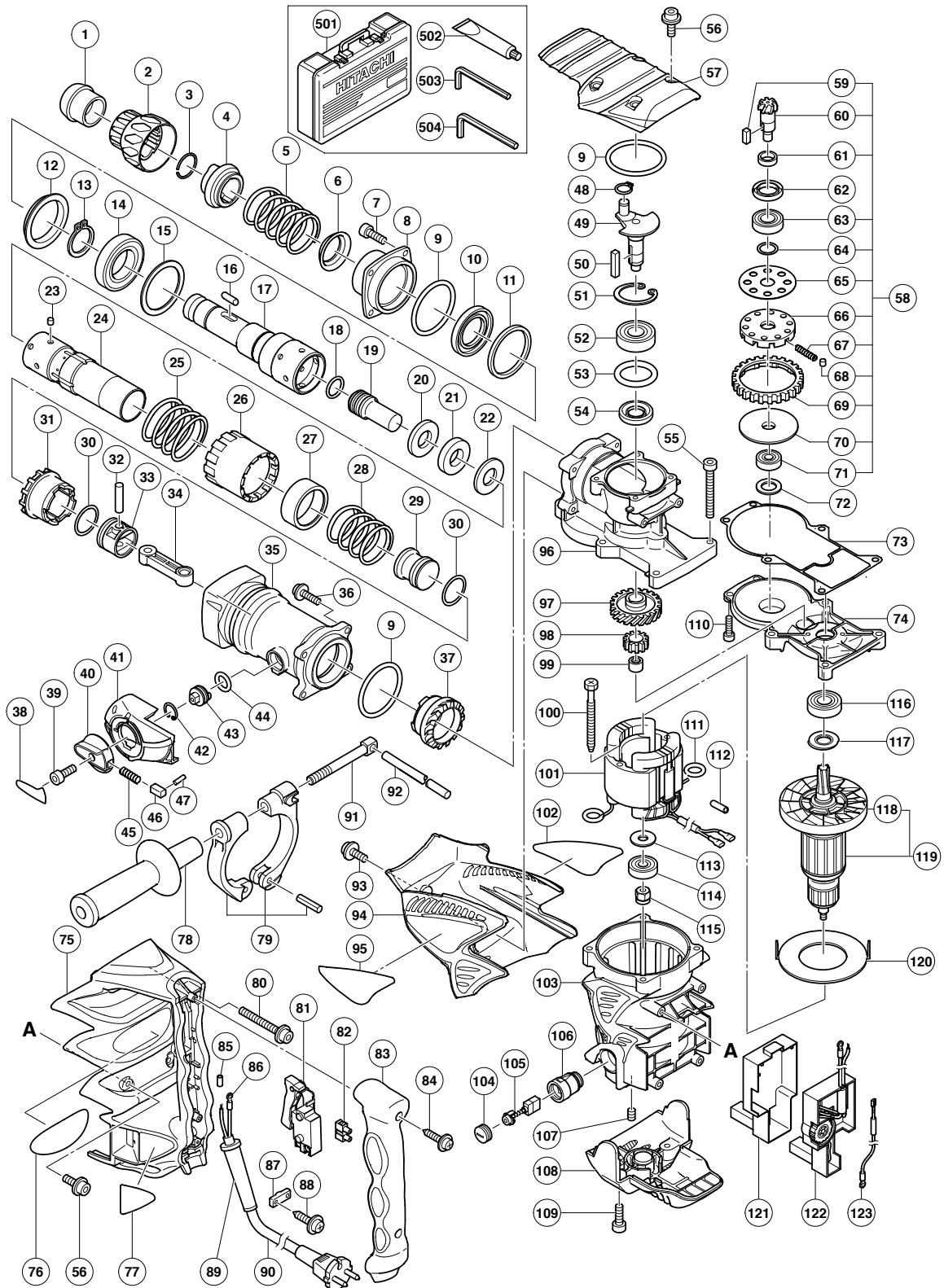

PARTS

DH 45MR

ITEM NO.	CODE NO.	DESCRIPTION	NO. USED	REMARKS
1	321-306	FRONT CAP	1	
2	321-305	GRIP	1	
3	318-590	STOPPER RING	1	
4	321-304	NEEDLE HOLDER	1	
5	321-303	RETAINER SPRING	1	
6	321-302	SPRING HOLDER (A)	1	
7	981-942	SEAL LOCK HEX. SOCKET HD. BOLT M6X25	4	
8	321-300	FRONT COVER	1	
9	956-996	O-RING (1AS-60)	3	
10	321-301	OIL SEAL	1	
11	325-229	RUBBER RING	1	
12	315-868	URETHANE RING HOLDER	1	
13	948-131	RETAINING RING FOR D35 SHAFT	1	
14	600-7DD	BALL BEARING 6007DDUAV2S	1	
15	321-297	BEARING WASHER	1	
16	313-421	NEEDLE ROLLER D8X20	2	
17	324-919	RETAINER SLEEVE	1	
18	324-921	O-RING (C)	1	
19	324-920	SECOND HAMMER	1	
20	324-922	DAMPER WASHER	1	
21	324-923	DAMPER	1	
22	324-924	DAMPER HOLDER	1	
23	313-057	NEEDLE PIN D6X6	4	
24	324-925	CYLINDER	1	
25	324-930	LOCK SPRING	1	
26	324-931	LOCK SLEEVE	1	
27	324-927	SPRING HOLDER (B)	1	
28	324-928	CLUTCH SPRING	1	
29	324-926	STRIKER	1	
30	324-918	O-RING (I.D 27.2)	2	
31	324-929	CLUTCH	1	
32	324-917	PISTON PIN	1	
33	324-915	PISTON	1	
34	324-916	CONNECTING ROD	1	
35	324-932	CYLINDER CASE	1	
36	991-712	HEX. SOCKET HD. BOLT (W/FLANGE) M6X25	4	
37	324-933	BEVEL GEAR	1	
38	321-867	LEVER LABEL	1	
39	983-162	SEAL LOCK HEX. SOCKET HD. BOLT M4X12	1	
40	321-309	CHANGE LEVER	1	
41	324-935	LEVER HOLDER	1	
42	311-229	RETAINING RING FOR D20 HOLE	1	
43	324-934	LEVER SHAFT	1	
44	873-095	O-RING (P-16)	1	
45	321-310	LEVER SPRING	1	
46	321-311	PUSHING BUTTON	1	
47	321-312	PIN D2X10	1	
48	939-540	RETAINING RING FOR D10 SHAFT (10 PCS.)	1	
49	324-909	CRANK SHAFT	1	
50	971-750	FEATHER KEY 3X3X20	1	
51	948-391	RETAINING RING FOR D40 HOLE	1	

PARTS

DH 45MR

ITEM NO.	CODE NO.	DESCRIPTION	NO. USED	REMARKS	
52	620-3DD	BALL BEARING 6203DDCMPS2L	1		
53	996-363	O-RING (S-40)	1		
54	971-745	OIL SEAL (A)	1		
55	986-940	SEAL LOCK HEX. SOCKET HD. BOLT M6X45	4		
56	994-192	HEX. SOCKET HD. BOLT (W/FLANGE) M5X16	8		
57	324-937	CRANK COVER	1		
58	324-912	SLIP CLUTCH ASS'Y	1	INCLUD. 59-61, 63-71	
59	944-109	FEATHER KEY 3X3X8	1		
60	324-913	BEVEL PINION	1		
61	321-279	COLLAR	1		
62	313-050	OIL SEAL (A)	1		
63	600-2DD	BALL BEARING 6002DDCMPS2L	1		
64	313-058	WASHER	1		
65	313-053	WASHER (A)	1		
66	321-281	GEAR HOLDER	1		
67	321-282	SPRING (C)	10		
68	320-343	NEEDLE	10		
69	324-914	SECOND GEAR	1		
70	321-283	SPACER	1		
71	629-VVM	BALL BEARING 629VVC2PS2L	1		
72	944-525	BEARING WASHER (C)	1		
73	325-230	SEAL PACKING	1		
74	324-944	GEAR COVER	1		
75	324-947	HANDLE	1		
76		NAME PLATE	1		
77	324-938	SDS MAX LABEL	1		
78	313-078	SIDE HANDLE	1		
79	313-079	HANDLE HOLDER	1		
80	980-673	HEX. SOCKET HD. BOLT (W/FLANGE) M5X40	2		
81	313-093	SWITCH (C) (2P SCREW TYPE W/O LOCK)	1		
82	938-307	PILLAR TERMINAL	1		
83	324-948	HANDLE COVER	1		
84	301-653	TAPPING SCREW (W/FLANGE) D4X20 (BLACK)	2		
*	85	981-373	TUBE (D)	2	FOR CORD
*	86	980-063	TERMINAL	1	
*	86	930-804	TERMINAL M4.0 (10 PCS.)	1	FOR GBR (110V), USA, CAN
*	87	960-266	CORD CLIP	1	
*	87	981-987Z	CORD CLIP	1	FOR SUI
88	984-750	TAPPING SCREW (W/FLANGE) D4X16	2		
*	89	953-327	CORD ARMOR D8.8	1	
*	89	938-051	CORD ARMOR D10.1	1	
*	90	500-390Z	CORD	1	(CORD ARMOR D10.1)
*	90	500-467Z	CORD	1	(CORD ARMOR D10.1) FOR GBR (110V)
*	90	500-446Z	CORD	1	(CORD ARMOR D10.1) FOR GBR (230V)
*	90	500-391Z	CORD	1	(CORD ARMOR D10.1) FOR SUI
*	90	500-434Z	CORD	1	(CORD ARMOR D10.1) FOR USA, CAN
*	90	500-439Z	CORD	1	(CORD ARMOR D8.8) FOR AUS
*	90	500-408Z	CORD	1	(CORD ARMOR D8.8) FOR NZL
91	313-080	HANDLE BOLT	1		
92	971-786	STOPPER ROD	1		
93	998-471	HEX. SOCKET HD. BOLT (W/FLANGE) M5X12	1		

STANDARD ACCESSORIES

DH 45MR

ITEM NO.	CODE NO.	DESCRIPTION	NO. USED	REMARKS
501	324-820	CASE (PLASTIC)	1	
502	981-840	GREASE (A) FOR HAMMER. HAMMER DRILL (30G)	1	
503	944-458	HEX. BAR WRENCH 4MM	1	
504	944-459	HEX. BAR WRENCH 5MM	1	

OPTIONAL ACCESSORIES

ITEM NO.	CODE NO.	DESCRIPTION	NO. USED	REMARKS
601	308-471	GREASE FOR HAMMER. HAMMER DRILL (70G)	1	
602	980-927	GREASE FOR HAMMER. HAMMER DRILL (500G)	1	
603	320-859	SYRINGE (BLOW-OUT BULB TYPE)	1	
604	318-085	SYRINGE (BELLOWS TYPE)	1	
605	313-448	DRILL BIT (SDS MAX) D16X340	1	
606	313-456	DRILL BIT (SDS MAX) D16X540	1	
607	313-449	DRILL BIT (SDS MAX) D19X340	1	
608	313-457	DRILL BIT (SDS MAX) D19X540	1	
609	313-450	DRILL BIT (SDS MAX) D22X320	1	
610	313-458	DRILL BIT (SDS MAX) D22X520	1	
611	313-451	DRILL BIT (SDS MAX) D25X320	1	
612	313-459	DRILL BIT (SDS MAX) D25X520	1	
613	313-452	DRILL BIT (SDS MAX) D28X370	1	
614	313-460	DRILL BIT (SDS MAX) D28X570	1	
615	313-453	DRILL BIT (SDS MAX) D32X370	1	
616	313-461	DRILL BIT (SDS MAX) D32X570	1	
617	313-454	DRILL BIT (SDS MAX) D38X370	1	
618	313-462	DRILL BIT (SDS MAX) D38X570	1	
619	313-455	DRILL BIT (SDS MAX) D40X370	1	
620	313-463	DRILL BIT (SDS MAX) D40X570	1	
621	944-460	TAPER SHANK DRILL BIT D11X100	1	
622	944-461	TAPER SHANK DRILL BIT D12.3X110	1	
623	993-038	TAPER SHANK DRILL BIT D12.7X110	1	
624	944-462	TAPER SHANK DRILL BIT D14.3X110	1	
625	944-500	TAPER SHANK DRILL BIT D14.5X110	1	
626	944-463	TAPER SHANK DRILL BIT D17.5X120	1	
627	313-464	TAPER SHANK ADAPTER ASS'Y (SDS MAX) NO. 1	1	INCLUD. 628
628	944-477	COTTER	1	
629	313-465	ADAPTER (SDS MAX) FOR SDS PLUS SHANK BIT	1	
630	955-994	CORE BIT 25MM	1	
631	955-995	CORE BIT 29MM	1	
632	955-996	CORE BIT 32MM	1	INCLUD. 633
633	955-997	GUIDE PLATE (FOR CORE BIT 32MM)	1	
634	955-998	CORE BIT 35MM	1	INCLUD. 635
635	955-999	GUIDE PLATE (FOR CORE BIT 35MM)	1	
636	956-000	CORE BIT 38MM	1	INCLUD. 637
637	956-001	GUIDE PLATE (FOR CORE BIT 38MM)	1	
638	955-154	CORE BIT 45MM	1	INCLUD. 639
639	955-166	GUIDE PLATE (FOR CORE BIT 45MM)	1	
640	955-155	CORE BIT 54MM	1	INCLUD. 641
641	955-167	GUIDE PLATE (FOR CORE BIT 54MM)	1	

