

ELECTRIC TOOL PARTS LIST

CORDLESS AUTOMATIC SCREW DRIVER
Model WF 14DSL

2011-9-8
(E1)

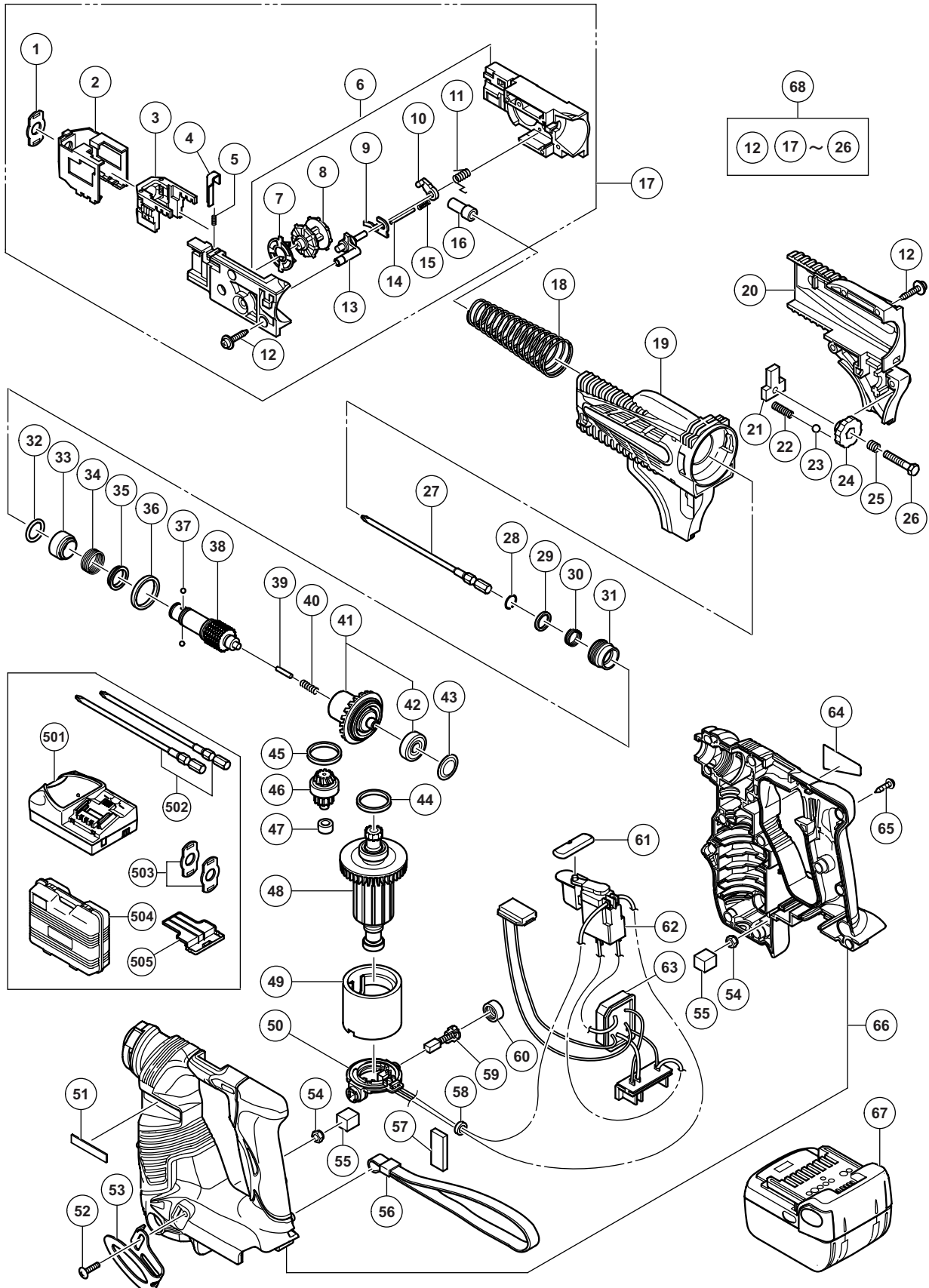

PARTS

WF 14DSL

ITEM NO.	CODE NO.	DESCRIPTION	NO. USED	REMARKS
1	332-455	SHEET (2 PCS.)	1	
2	324-863	STOPPER	1	
3	324-177	GUIDE BLOCK	1	
4	324-184	PLATE (A)	1	
5	324-185	SPRING (C)	1	
6	324-165	SLIDER (A).(B) SET	1	
7	324-175	CLUTCH PLATE	1	
8	324-167	SPROCKET	1	
9	324-176	STOPPER PLATE	1	
10	324-173	ARM (B)	1	
11	324-174	ARM SPRING	1	
12	301-653	TAPPING SCREW (W/FLANGE) D4 X 20 (BLACK)	6	
13	324-169	ARM	1	
14	885-349	PIN D2.5	1	
15	324-489	SPRING	1	
16	324-186	METAL (F)	1	
17	324-164	SLIDER ASS'Y	1	INCLUD. 1-16
18	324-190	SPRING	1	
19	324-162	SLIDER CASE (A)	1	
20	324-163	SLIDER CASE (B)	1	
21	324-189	STOPPER PIN	1	
22	324-191	SPRING (A)	1	
23	959-148	STEEL BALL D3.175 (10 PCS.)	1	
24	324-187	KNOB	1	
25	312-430	SPRING	1	
26	324-188	BOLT M5	1	
27	324-134	+ DRIVER BIT NO. 2 136.4L	1	
28	330-619	RETAINING RING	1	
29	330-618	WASHER (D)	1	
30	330-617	GUIDE SPRING (C)	1	
31	322-717	GUIDE SLEEVE (D)	1	
32	317-662	O-RING (F)	1	
33	332-465	METAL (F)	1	
34	330-162	STOPPING SPRING	1	
35	330-163	LOCKING FLANGE	1	
36	334-270	DRUM METAL	1	
37	319-535	STEEL BALL D3.5 (10 PCS.)	2	
38	332-461	SOCKET (A)	1	
39	330-164	RUBBER SHAFT	1	
40	329-642	SPRING (C)	1	
41	332-464	CLUTCH DRUM ASS'Y	1	INCLUD. 42
42	608-VVM	BALL BEARING 608VVC2PS2L	1	
43	313-153	THRUST PLATE	1	
44	323-420	RUBBER RING	1	
45	323-420	RUBBER RING	1	
46	332-463	SECOND PINION SET	1	
47	324-150	NEEDLE BEARING	1	
48	332-466	ARMATURE PINION SET	1	
49	333-735	MAGNET	1	
50	332-460	BRUSH BLOCK	1	

