

## ELECTRIC TOOL PARTS LIST

■ CORDLESS ANGLE IMPACT DRIVER 1994 · 3 · 10  
Model WH 8DYA (E1)

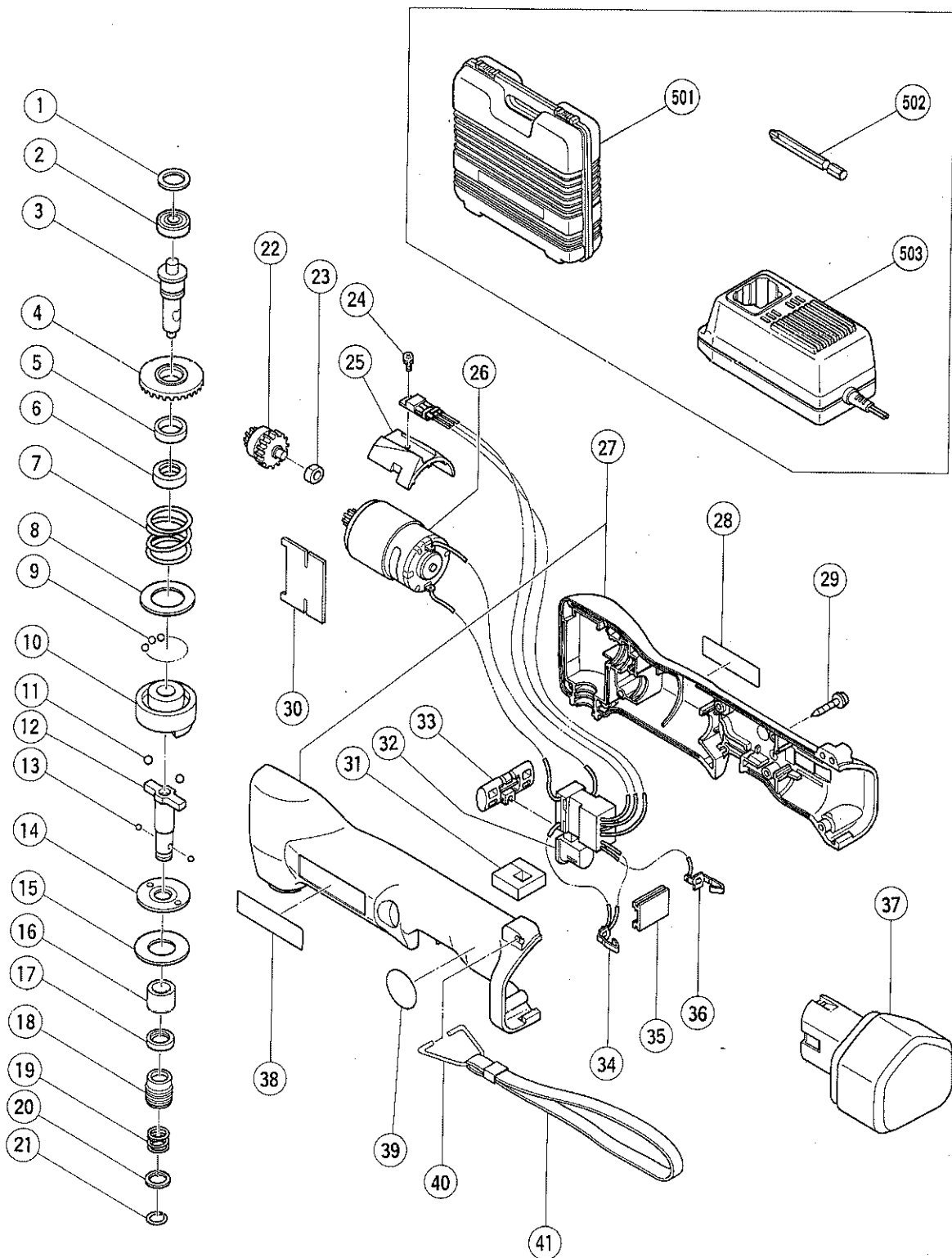

## PARTS

WH 8DYA

ITEM NO.	CODE NO.	DESCRIPTION	NO. USED	REMARKS
1	933-545	WASHER (A)	1	
2	608-VVM	BALL BEARING 608VVMC2EPS2L	1	
3	308-497	SPINDLE	1	
4	308-495	FINAL GEAR	1	
5	941-732	WASHER (A)	1	
6	302-335	STOPPER	1	
7	308-498	SPRING	1	
8	302-331	WASHER (G)	1	
9	959-155	STEEL BALL D3.97 (10 PCS.)	21	
10	302-330	HAMMER	1	
11	959-154	STEEL BALL D5.556 (10 PCS.)	2	
12	309-171	ANVIL (H)	1	
13	959-148	STEEL BALL D3.175 (10 PCS.)	2	
14	302-329	WASHER (F)	1	
15	302-328	RUBBER WASHER	1	
16	302-327	METAL	1	
17	302-326	OIL SEAL	1	
18	307-782	GUIDE SLEEVE (A)	1	
19	995-931	GUIDE SPRING	1	
20	307-899	RETAINER	1	
21	995-933	RETAINING RING	1	
22	308-496	SECOND PINION	1	
23	997-752	METAL	1	
24	301-791	MACHINE SCREW (W/SP. WASHER) M3.5X6	1	
25	308-500	FIN	1	
26	308-499	MOTOR	1	
27	308-502	HOUSING (A),(B) SET	1	
* 28		NAME PLATE	1	
29	302-086	TAPPING SCREW (W/FLANGE) D4X20 (BLACK)	9	
30	309-178	RUBBER SHEET	1	
31	306-157	SEAL	1	
32	306-153	SWITCH ASS'Y (1P PLUG IN TYPE) W/O LOCK	1	INCLUD.34,36
33	306-151	PUSHING BUTTON	1	
34	306-155	TERMINAL (A)	1	
35	991-666	TERMINAL SUPPORT	1	
36	306-154	TERMINAL	1	
* 37	991-642Z	BATTERY EB 9 (W/ENGLISH N.P.)	1	FOR GBR
* 37	991-641Z	BATTERY EB 9 (W/GERMAN N.P.)	1	FOR FRG
* 37	991-643Z	BATTERY EB 9 (W/FRENCH N.P.)	1	FOR FRA
* 37	991-644Z	BATTERY EB 9 (W/ENGLISH N.P.)	1	FOR USA
* 37	991-681	BATTERY EB 9 (W/ENGLISH N.P.)	1	FOR HOL
* 37	991-683	BATTERY EB 9 (W/GERMAN N.P.)	1	FOR BEL
* 37	991-685	BATTERY EB 9 (W/ITALIAN N.P.)	1	FOR ITA
38		HITACHI LABEL	1	
39	987-135	MARK PLATE	1	
40	980-838	HOOK	1	
41	306-952	STRAP	1	

\*: ALTERNATIVE PARTS

### STANDARD ACCESSORIES

WH 8DYA

ITEM NO.	CODE NO.	DESCRIPTION	NO. USED	REMARKS
501	308-314	CASE	1	
502	992-671	+ DRIVER BIT (B) NO.2 50L	1	
503		CHARGER (MODEL UC 12Y)	1	

### OPTIONAL ACCESSORIES

ITEM NO.	CODE NO.	DESCRIPTION	NO. USED	REMARKS
601	992-672	+ DRIVER BIT (B) NO.3 50L	1	
602	996-177	NON – MAGNETIC HEX. SOCKET 8MM 65L	1	
603	985-329	NON – MAGNETIC HEX. SOCKET 10MM 65L	1	
604	996-178	NON – MAGNETIC HEX. SOCKET 12MM 65L	1	
605	996-179	NON – MAGNETIC HEX. SOCKET 13MM 65L	1	
606	996-180	NON – MAGNETIC HEX. SOCKET 14MM 65L	1	
607	996-185	NON – MAGNETIC HEX. SOCKET 15MM 65L	1	
608	996-181	NON – MAGNETIC HEX. SOCKET 16MM 65L	1	
609	996-182	NON – MAGNETIC HEX. SOCKET 17MM 65L	1	
610	996-186	NON – MAGNETIC HEX. SOCKET 19MM 65L	1	
611	959-183	DRILL BIT FOR WOOD (HEX. SHAFT) D14X83	1	
612	996-197	HEX. SOCKET (LONG) 21MMX166L	1	
613	996-195	DRILL CHUCK AND ADAPTER SET	1	
614	308-090	HOOK (FOR CORDLESS TOOLS)	1	
615	971-042	GREASE FOR IMPACT WRENCH (100G)	1	

\*: ALTERNATIVE PARTS